

RELIANCE

4L “R” Style Bottle

026 series (48mm or 63mm neck) 027 series (38mm neck) Mold Number(s): 172A/B

An oblong (“F” style) bottle made of High Density Polyethylene. The package is ideal for use as a shipping container for a wide range of Chemicals and numerous general uses.

PERFORMANCE SPECIFICATIONS

- No objection status for food contact applications from the Health Protection Branch in Canada and compliance for use in food contact applications by the Food and Drug Administration in the United States. Black bottles excluded.
- UN classification for transportation of Group II or III liquid fill dangerous goods when used in conjunction with appropriate cap and carton (see sales specification SS-UN-017). Classification is good for land, sea and air transport. Compatibility of fill product with container is the responsibility of the filler.

DIMENSIONS

Capacity	Rated 4.0L	Overflow (to top of neck) 4.3L minimum	
Weight	Bottle Only 153.0g ± 5.0g		
Dimensions	Length 7.0”	Width 4.2”	
	Height 11.8”	Minimum Wall Thickness 0.020”	
Panel Dimensions	(Flat Sections) L x W x H 6.0” x 3.0” x 6.6”	Circumference of Panel 19.8”	

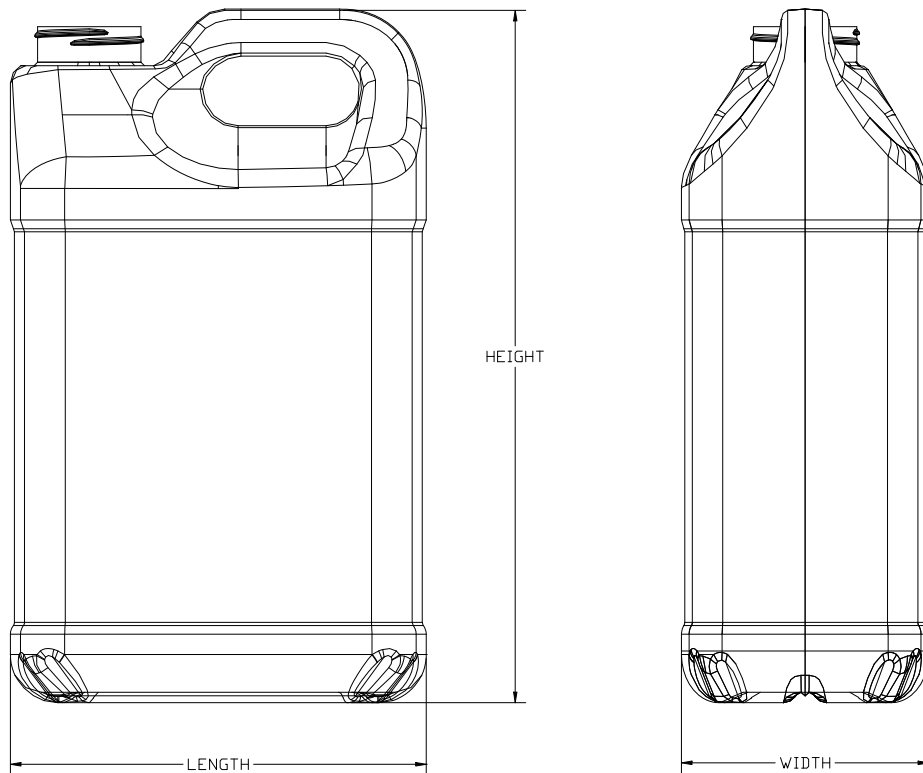

SPECIAL FEATURES

Neck Finishes	38mm neck, designed for SP 400 cap, with ratchet for one-piece child-resistant caps or 48mm neck, designed for SP 400 cap and 63mm neck is designed for SP 400.
Closures	Will accept induction seals.
Barrier Properties	Available with Barrier Pak in-line fluorination to reduce the permeation of aggressive formulas. See our Barrier Pak specification (SS-BP-001) for details.
Decorating	Bottles may be flamed on the recessed panels to improve adhesion. Bottles may also be custom sleeved on line or post labelled at an extra charge.
Packaging	Bottles may be delivered in shipper cartons or pallets. Shipper carton quotes based on carton specifications.

FILLING RECOMMENDATIONS

- Compatibility of the bottle with the fill product is the responsibility of the filler.
- Contents should not exceed 70°C (158°F) at time of fill.
- Filled containers should not be stacked and stored above 50°C (122°F).

For **Stacking Recommendations** please contact the Reliance Quality Department at (204) 633-4403 ext. 229

PACKAGING AND SHIPPING DATA

Quantity Per Pallet	Bulk
Package Weight	264 pieces
Shipping Dimensions (L x W x H)	99.9 lbs.
Shipping Volume (Cubic Feet)	48.38" x 43.38" x 47.89"
	58.1

Packaging includes top and bottom corrugate trays, secured with strapping and stretch wrap.

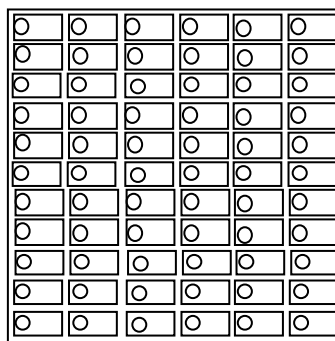
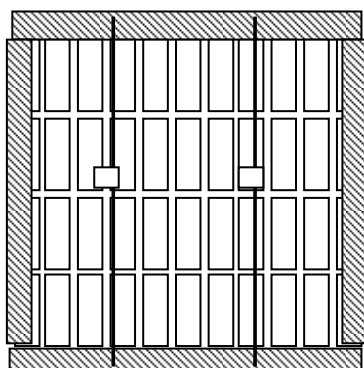
**WARRANTY**

Reliance Products L.P. warrants product to meet the above specifications and to be free from defect in workmanship and materials at time of shipment. Liability is limited to the replacement cost of the containers purchased. Reliance Products LP does not test specific product packaging requirements and as such, customers are required to assure packaging meets the legal, environmental and containment needs of the product being packaged.

PRODUCT RANGE

Reliance Products L.P. has many decades of experience manufacturing a wide range of both injection and blow moulded plastic shipping containers, including:

Bottles	1L to 23L	Tighthead Containers	10L to 23L
Pails	4L to 23L	Collapsible Containers	10L to 25L

Call us for all of your related packaging needs