

RELIANCE

10L No Glug Rigid Pak

030 series

Mold Number(s): R434 A1 / A2, R433C

A 10L heavy duty, oblong bottle made of High Density Polyethylene. The package is ideal for use as a shipping container for a wide range of Chemicals and numerous general uses. The No Glug design provides safe, splash free pouring, while decreasing the time required to empty the bottle contents.

PERFORMANCE SPECIFICATIONS

- No objection status for food contact applications from the Health Protection Branch in Canada and compliance for use in food contact applications by the Food and Drug Administration in the United States. Black bottles excluded.

DIMENSIONS

Capacity	Rated	10.0L	Overflow (to top of neck)	11.18L minimum
Weight	Bottle Only	330.0g ± 10.0g		
Dimensions	Length	9.162" ± 0.030"	Width	6.796" ± 0.030"
	Height to neck	15.230" ± 0.030"	Height to handle	15.377" ± 0.030"
Panel Dimensions	Minimum Wall Thickness	0.023"		
	(Flat Sections) L x W x H	8.986" x 6.619" x	Circumference of Panel	28.0"
		7.766"		

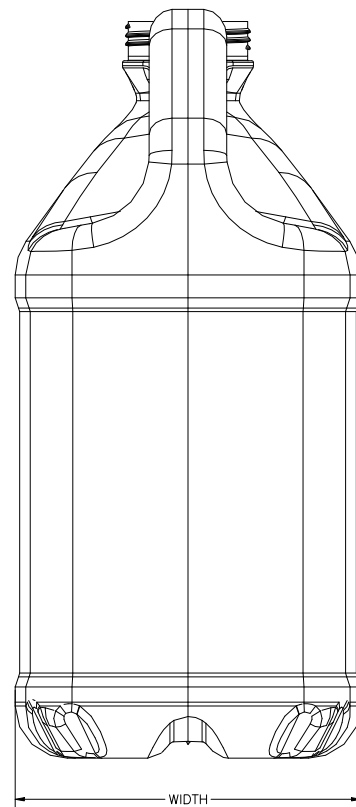
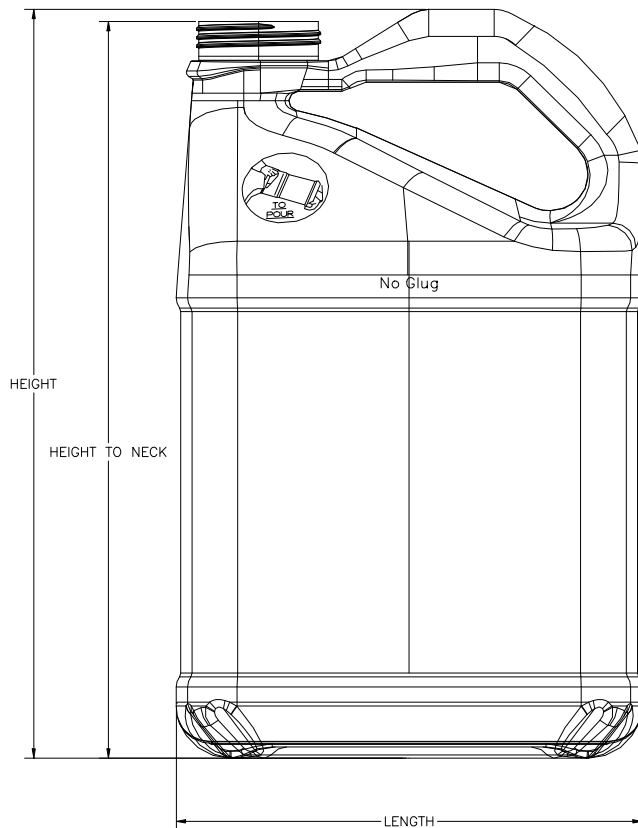

SPECIAL FEATURES

- Neck Finishes 63mm neck, designed for Rieke 63mm Screw Caps
- Closures Will accept induction seals. Spigots and vented caps are available.
- Barrier Properties Available with **Barrier Pak** in-line **fluorination** (*standard level 2*) to reduce the permeation of aggressive formulas. *Higher levels of fluorination (up to level 5) can accomplish if required, ask your sales rep for more information.* See our Barrier Pak specification (SS-BP-001) for details.
- Decorating Bottles may be flamed on the recessed panels to improve adhesion. Bottles may also be custom sleeved on line or post labelled at an extra charge.
- Packaging Bottles may be delivered in shipper cartons or palletized. Shipper carton quotes based on carton specifications.

FILLING RECOMMENDATIONS

- Compatibility of the bottle with the fill product is the responsibility of the filler.
- Contents should not exceed 70°C (158°F) at time of fill.
- Filled containers should not be stacked and stored above 50°C (122°F).

For **Stacking Recommendations** please contact the Reliance Quality Department at (204) 633-4403 ext. 229

PACKAGING AND SHIPPING DATA

Quantity Per Pallet	<u>Bulk – 105 Pak</u>
Package Weight	105 pieces
Shipping Dimensions (L x W x H)	84.8 lbs.
Shipping Volume (Cubic Feet)	47.75” x 46.25” x 48”
	61.35

Packaging includes top and bottom corrugate trays, secured with strapping and stretch wrap.

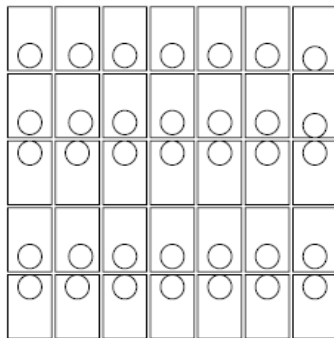

Top View of Pallet

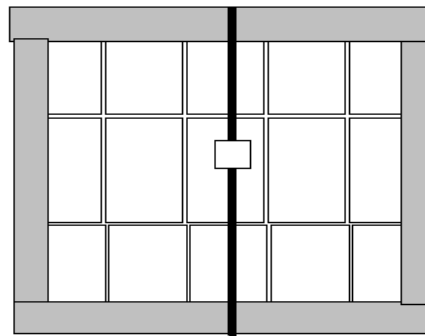

Side View of 105 Pak Pallet

WARRANTY

Reliance Products L.P. warrants product to meet the above specifications and to be free from defect in workmanship and materials at time of shipment. Liability is limited to the replacement cost of the containers purchased. Reliance Products LP does not test specific product packaging requirements and as such, customers are required to assure packaging meets the legal, environmental and containment needs of the product being packaged.

PRODUCT RANGE

Reliance Products L.P. has many decades of experience manufacturing a wide range of both injection and blow moulded plastic shipping containers, including:

Bottles	1L to 23L	Tighthead Containers	10L to 23L
Pails	4L to 23L	Collapsible Containers	10L to 25L

Call us for all of your related packaging needs