



**8L Clean Flow™ Bottle**

053 series

Mold Number(s): R434

A 8L heavy duty, oblong bottle made of High Density Polyethylene. The package is ideal for use as a shipping container for a wide range of Chemicals and numerous general uses.

This patent pending design features a Pinched Handle AND a No-Glug feature. The pinched handle prevents product from crystallizing in the handle, which can lead to clogged spray nozzle tips. This feature also makes cleaning easier prior to disposal. The no-glug offers an innovative breather tube that makes pouring smooth and simple. This eliminates costly and sometimes hazardous splashing of chemicals.

**PERFORMANCE SPECIFICATIONS**

- No objection status for food contact applications from the Health Protection Branch in Canada and compliance for use in food contact applications by the Food and Drug Administration in the United States. Black bottles excluded.

**DIMENSIONS**

<b>Capacity</b>	<b>Rated</b>	8.0L	<b>Overflow (to top of neck)</b>	8.9 L minimum
<b>Weight</b>	<b>Bottle Only</b>	315.0g ± 10.0g		
<b>Dimensions</b>	<b>Length</b>	9.16"	<b>Width</b>	6.80"
	<b>Height to neck</b>	12.90"	<b>Height to handle</b>	13.05"
	<b>Minimum Wall Thickness</b>	0.023"		
<b>Panel</b>	<b>Height</b>	6.15"	<b>Circumference</b>	28.0"

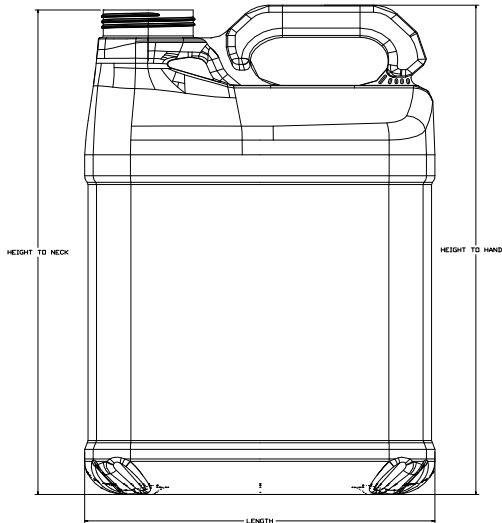
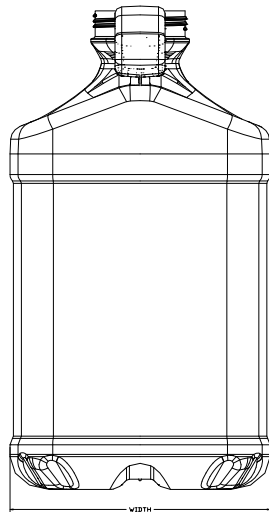

**SPECIAL FEATURES**

Neck Finishes	63mm neck designed for Rieke FS-632 and FS-641 Screw Caps
Closures	Will accept induction seals. Vented caps available.
Barrier Properties	Available with <b>Barrier Pak</b> in-line <b>fluorination</b> ( <i>standard level 2</i> ) to reduce the permeation of aggressive formulas. <i>Higher levels of fluorination (up to level 5) can accomplish if required, ask your sales rep for more information.</i> See our Barrier Pak specification (SS-BP-001) for details.
Decorating	Bottles may be flamed on the recessed panels to improve adhesion. Bottles may also be custom sleeved on line or post labelled at an extra charge.
Packaging	Bottles may be delivered in shipper cartons or palletized. Shipper carton quotes based on carton specifications.

**FILLING RECOMMENDATIONS**

- Compatibility of the bottle with the fill product is the responsibility of the filler.
- Contents should not exceed 70°C (158°F) at time of fill.
- Filled containers should not be stacked and stored above 50°C (122°F).

For **Stacking Recommendations** please contact the Reliance Quality Department at (204) 633-4403 ext. 229

**PACKAGING AND SHIPPING DATA**

	<u><b>Bulk – 105 Pak</b></u>	<u><b>Bulk – 140 Pak</b></u>
<b>Quantity Per Pallet</b>	105 pieces	140 pieces
<b>Package Weight</b>	93.0 lbs.	121.2 lbs.
<b>Shipping Dimensions (L x W x H)</b>	47.75" x 46.25" x 39.65"	47.75" x 46.25" x 52.83"
<b>Shipping Volume (Cubic Feet)</b>	50.7	67.5

Packaging includes top and bottom corrugate trays, secured with strapping and stretch wrap.

**WARRANTY**

Reliance Products L.P. warrants product to meet the above specifications and to be free from defect in workmanship and materials at time of shipment. Liability is limited to the replacement cost of the containers purchased. Reliance Products LP does not test specific product packaging requirements and as such, customers are required to assure packaging meets the legal, environmental and containment needs of the product being packaged.

**PRODUCT RANGE**

Reliance Products L.P. has many decades of experience manufacturing a wide range of both injection and blow moulded plastic shipping containers, including:

Bottles	1L to 23L	Tighthead Containers	10L to 23L
Pails	4L to 23L	Collapsible Containers	10L to 25L

Call us for all of your related packaging needs