

RELIANCE

13.5L R Style Bottle

043 series

Mold Number(s): R-401A, R-401B

A 13.5L heavy duty, custom bottle made of High Density Polyethylene. The package is ideal for use as a shipping container for a wide range of Chemicals and numerous general uses.

PERFORMANCE SPECIFICATIONS

- No objection status for food contact applications from the Health Protection Branch in Canada and compliance for use in food contact applications by the Food and Drug Administration in the United States.

DIMENSIONS

Capacity	Rated	13.5L	Overflow (to top of neck)	16.09 minimum
Weight	Bottle Only	545 ± 20.0g		
Dimensions	Length	9.072"	Width	8.982"
	Height to neck	15.739"	Height to handle	15.755"
	Minimum Wall Thickness	0.023"		
Panel Dimensions	(Flat Sections) L x W x H	7.1" x 5.0" x 8.0"	Circumference of Panel	32.0"

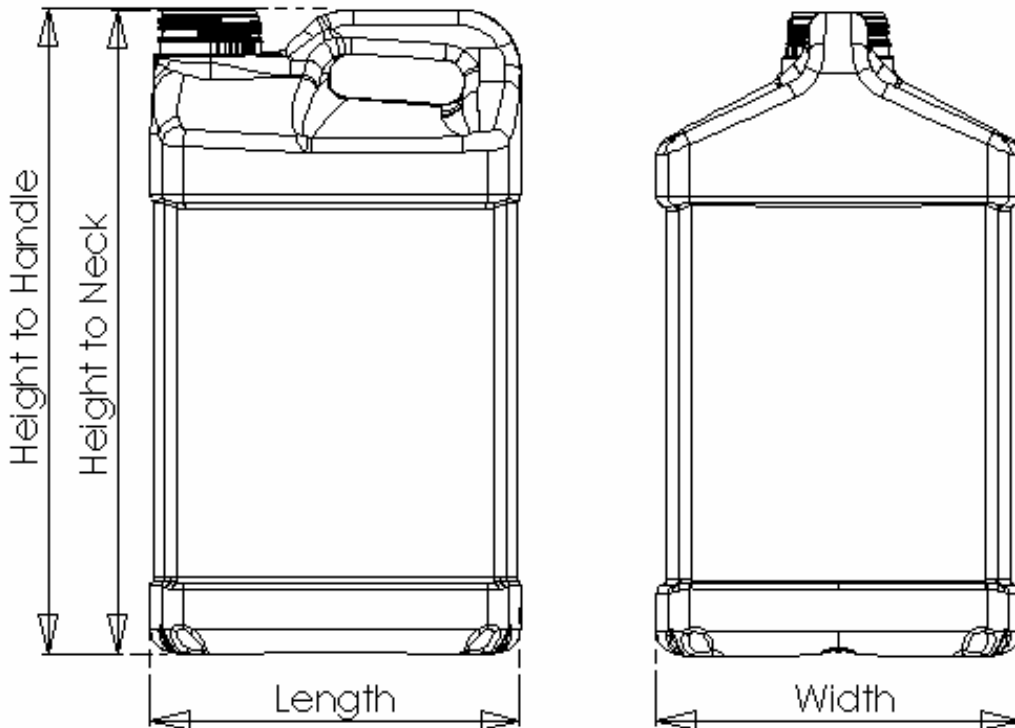

SPECIAL FEATURES

Neck Finishes 63mm neck designed for Rieke Screw SC-63-TE Caps. Will accept induction seals.
 Decorating Bottles may be flamed on the recessed panels to improve adhesion of labels. Bottles may also be custom sleeved on line or post labelled for an extra charge.

FILLING AND STACKING RECOMMENDATIONS

- Compatibility of the bottle with the fill product is the responsibility of the filler.
- Contents should not exceed 70°C (158°F) at time of fill.
- Filled containers should not be stacked and stored above 50°C (122°F).

PACKAGING AND SHIPPING DATA

	<u>Bulk</u>
Quantity Per Pallet	75 pieces
Package Weight	100.84 lbs.
Shipping Dimensions (L x W x H)	44.5" x 46" x 48"
Shipping Volume (Cubic Feet)	56.86

Packaging includes top and bottom corrugate trays, secured with strapping and stretch wrap.

WARRANTY

Reliance Products L.P. warrants product to meet the above specifications and to be free from defect in workmanship and materials at time of shipment. Liability is limited to the replacement cost of the containers purchased.

PRODUCT RANGE

Reliance Products L.P. has many decades of experience manufacturing a wide range of both injection and blow moulded plastic shipping containers, including:

Bottles	1L to 23L	Tighthead Containers	10L to 23L
Pails	4L to 23L	Collapsible Containers	10L to 25L

[Call us for all of your related packaging needs](#)