



## 14L Beam Pail

365 series

Mold Number(s): 65A

A 14L open head industrial pail with swing handle. Injection moulded from high density polyethylene resin, the pail tapers to allow nesting. The package is designed for use as a shipping container for a wide range of industrial and food service products where high strength and performance are desired.

### PERFORMANCE SPECIFICATIONS

- No objection status for food contact applications from the Health Protection Branch in Canada and compliance for use in food contact applications by the Food and Drug Administration in the United States. Black pails excluded.

### DIMENSIONS

<b>Capacity</b>	<b>Rated</b>	14.0L	<b>Overflow</b>	14.9L minimum
<b>Fill Volume</b>	<b>With 27 Series Lid</b>	14.3L	<b>With 91 Series Lid</b>	14.1L
<b>Weight</b>	<b>Pail Only</b>	605.0g ± 10.0g		
<b>Dimensions</b>	<b>Overall Height</b>	10.36 ± 0.025"		
	<b>Height With 27 Series Lid</b>	10.60 ± 0.025"	<b>Height With 91 Series Lid</b>	10.40 ± 0.025"
	<b>Nominal Wall Thickness</b>	0.075"		
	<b>Top Diameter</b>	11.885 ± 0.025"	<b>Bottom Diameter</b>	10.36 ± 0.025"

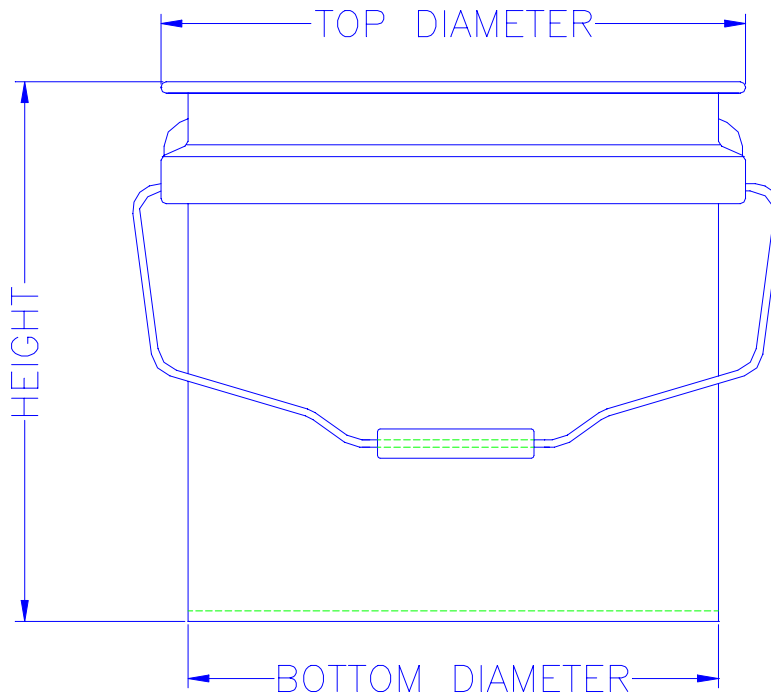

Approved By Ken Hall

## SPECIAL FEATURES

Lid Recommendations	27 series gasketed lid is recommended for use in liquid applications. 91 series Snap-Tite lid for use with powders or gels.
Decorating	The pail is flame treated to improve adhesion of labels and inks. Reliance offers offset printing in 1 to 6 colours on a custom basis. Printable area is 7" high by 34" in average circumference
Handle	The handle is a 9 gauge steel swing handle complete with plastic bail <i>or an industrial plastic handle.</i>

## FILLING AND STACKING RECOMMENDATIONS

- Compatibility of the pail and lid with fill product is the responsibility of the filler.
- Contents should not exceed 70°C (158°F) at time of fill.
- Filled containers should not be stacked and stored above 50°C (122°F).
- When affixing the lid to the pail, it is recommended that the centre of the lid be depressed to expel excess air from the container - commonly referred to as "burping".
- Maximum stack height of 6 pails when using 27 series lid, at a fill weight of 14.0 kg (30.8 lbs.) per pail.
- Palletization - 12 pails per layer in a 3 x 4 pattern on a standard 40" x 48" pallet. The use of double faced pallets is recommended, with stacks evenly spaced in such a manner that no pail overhangs the edges of the pallet. Pallet loads should be strapped and/or stretch wrapped to secure the load.

## PACKAGING AND SHIPPING DATA

<b>Quantity Per Pallet</b>	216 pieces
<b>Package Weight (for pails with handles)</b>	314.4 lbs.
<b>Shipping Dimensions (L x W x H)</b>	48.75" x 37.75" X 48.86"
<b>Shipping Volume (Cubic Feet)</b>	52.0

Packaging includes top and bottom corrugate trays, secured with strapping and stretch wrap.

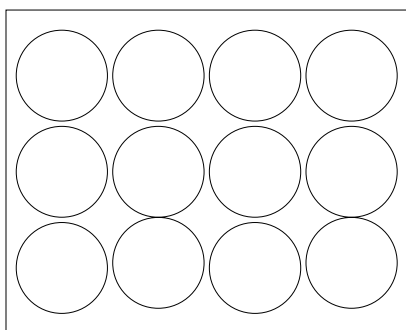

Top View of Pallet

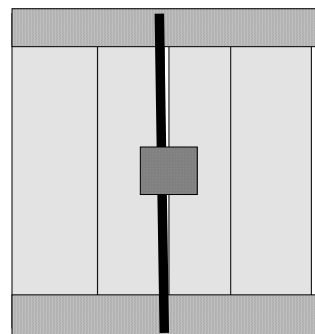

Side View of Pallet

## WARRANTY

Reliance Products L.P. warrants product to meet the above specifications and to be free from defect in workmanship and materials at time of shipment. Liability is limited to the replacement cost of the containers purchased.

## PRODUCT RANGE

Reliance Products L.P. has many decades of experience manufacturing a wide range of both injection and blow moulded plastic shipping containers, including:

Bottles	1L to 23L	Tighthead Containers	10L to 23L
Pails	4L to 23L	Collapsible Containers	10L to 25L

[Call us for all of your related packaging needs](#)