



**5L “R” Style Rigid Pak - Market Weight**

0501 series

Mold Number(s): R430

A 5L oblong (“F” style) bottle made of High Density Polyethylene. The package is ideal for use as a shipping container for a wide range of Chemicals and numerous general uses.

**PERFORMANCE SPECIFICATIONS**

- No objection status for food contact applications from the Health Protection Branch in Canada and compliance for use in food contact applications by the Food and Drug Administration in the United States. Black bottles excluded.

**DIMENSIONS**

<b>Capacity</b>	<b>Rated</b> 5.0L	<b>Overflow (to top of neck)</b> 5.50L minimum
<b>Weight</b>	<b>Bottle Only</b> 190g +60g -15g	
<b>Dimensions</b>	<b>Length</b> 9.162”	<b>Width</b> 6.796”
	<b>Height to neck</b> 8.589”	<b>Height to handle</b> 8.829”
	<b>Minimum Wall Thickness</b> 0.018”	
	<b>Panel Height</b> 2.3”	<b>Circumference</b> 28.0”

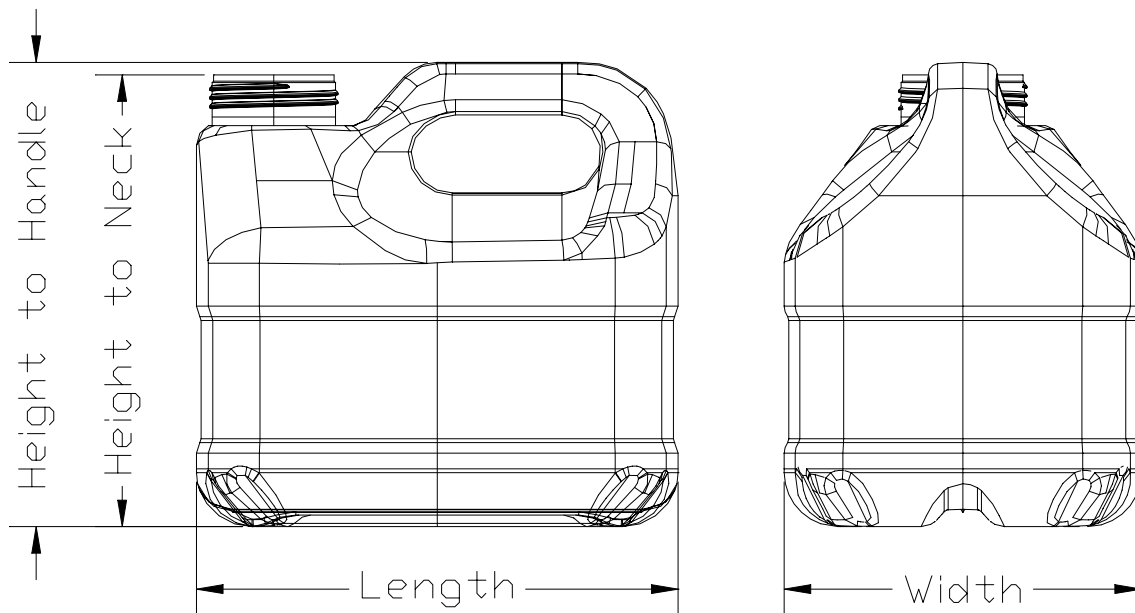

Shown with 63mm neck

**SPECIAL FEATURES**

- Neck Finishes      Standard – 63mm neck designed for Rieke FS-632 and FS-641 Screw Caps  
                           Custom – 63mm neck designed for Rexam 63mm-DCR Cap  
                           Custom – 38mm neck designed for SP 400 caps.
- Closures            Will accept induction seals. Spigots and vented caps available.
- Decorating         Bottles may be flamed on the recessed panels to improve adhesion. Bottles may also be custom sleeved on line or post labelled at an extra charge.
- Packaging          Bottles may be delivered in shipper cartons or palletized. Shipper carton quotes based on carton specifications.

**FILLING AND STACKING RECOMMENDATIONS**

- Compatibility of the bottle with the fill product is the responsibility of the filler.
- Contents should not exceed 70°C (158°F) at time of fill.
- Filled containers should not be stacked and stored above 50°C (122°F).
- Filled containers, based on contents of 5 kg (11 lbs.) per container, may be stacked as follows:
  - Single wall carton.....4 high, 2 bottles per carton
  - Double wall carton..... 6 high, 2 bottles per carton

**PACKAGING AND SHIPPING DATA**

<b>Quantity Per Pallet</b>	<b>Bulk</b>
<b>Package Weight</b>	175 pieces
<b>Shipping Dimensions (L x W x H)</b>	84.3 lbs.
<b>Shipping Volume (Cubic Feet)</b>	47.75" x 46.25" x 44.90"
	57.4

Packaging includes top and bottom corrugate trays, secured with strapping and stretch wrap.

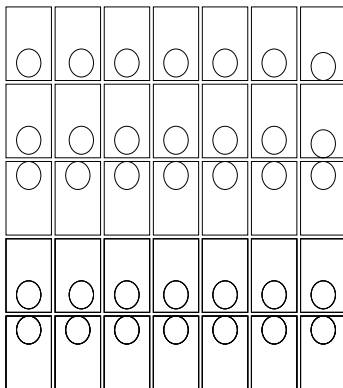

Top View of Pallet

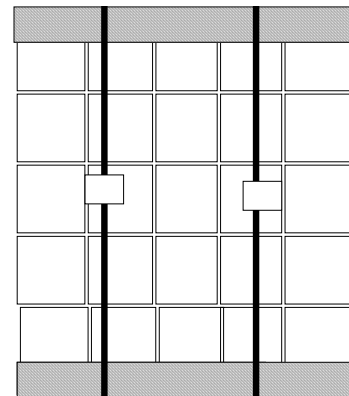

Side View of Pallet

**WARRANTY**

Reliance Products L.P. warrants product to meet the above specifications and to be free from defect in workmanship and materials at time of shipment. Liability is limited to the replacement cost of the containers purchased.

**PRODUCT RANGE**

Reliance Products L.P. has many decades of experience manufacturing a wide range of both injection and blow moulded plastic shipping containers, including:

Bottles	1L to 23L	Tighthead Containers	10L to 23L
Pails	4L to 23L	Collapsible Containers	10L to 25L

Call us for all of your related packaging needs